

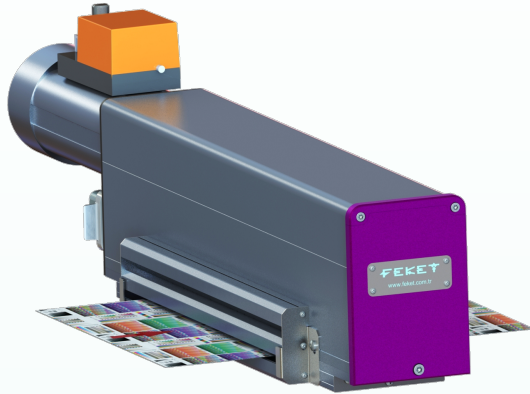

FEKET F72 NARROW WEB CONVENTIONAL UV SYSTEM

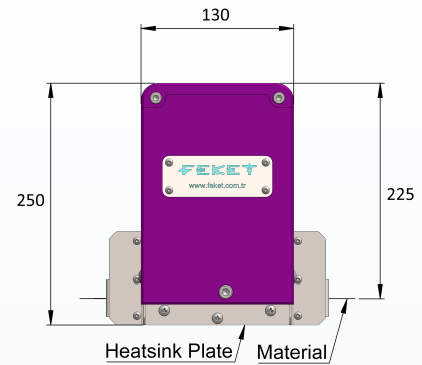

UV LAMP HEAD DIMENSIONS



Electronic Ballast



Operating Touch Screen Panel

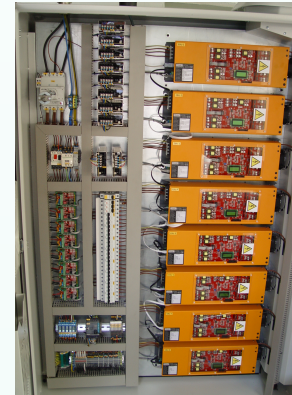

Main Electrical Cabinet

Features

- Extruded aluminium body.
- 80 to 200 w/cm power options.
- Slide out cassette system.
- Dichroic cold glass reflectors.(Option)
- IR blocker glass.(Option)
- Touch screen operating panel.
- Stepless power control facility.
- Electronic ballast units.
- The highest productivity and the minimum energy loss with the special reflector design.
- Maximum uv energy dose to the printing surface.
- The heat absorber cold glass reflectors provide the heat transfer to the aluminium reflectors.

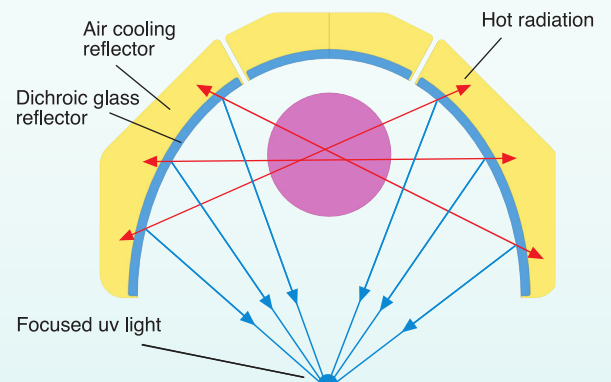

Highly Efficient Reflector Design